

**KIT FEATURES**

- ▶ Shaft and DIN unit provisions
- ▶ Equalizer provisions

**KIT COMPONENTS**

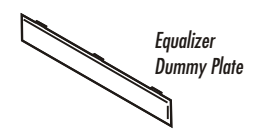
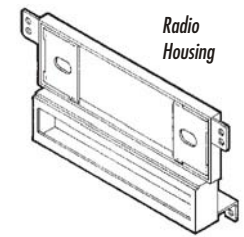

**TOOLS REQUIRED**



Phillips screwdriver



Cutting tool



Socket wrench

# 99-8110

## INSTALLATION INSTRUCTIONS

**APPLICATIONS**

<b>CAR</b>	<b>PAGE</b>
<b>TOYOTA</b>	
Tercel 1995-98.....	1-2
Paseo 1996-97.....	1-2



## ALL VEHICLES

1

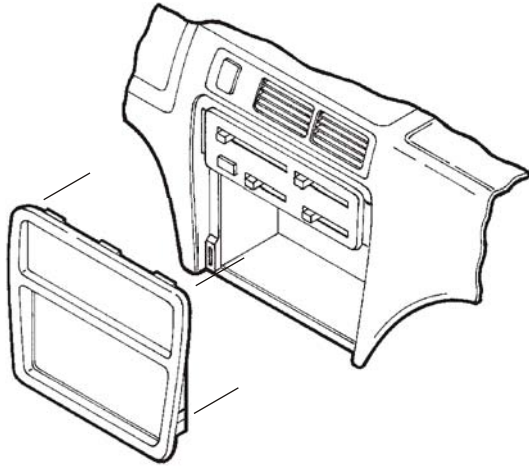

Disconnect the negative battery terminal to prevent an accidental short circuit. Unclip the bottom of the radio trim bezel. Unhook the top of the radio trim bezel and remove the bezel. Remove (4) 8mm Phillips screws securing the factory head unit and disconnect the wiring.

2

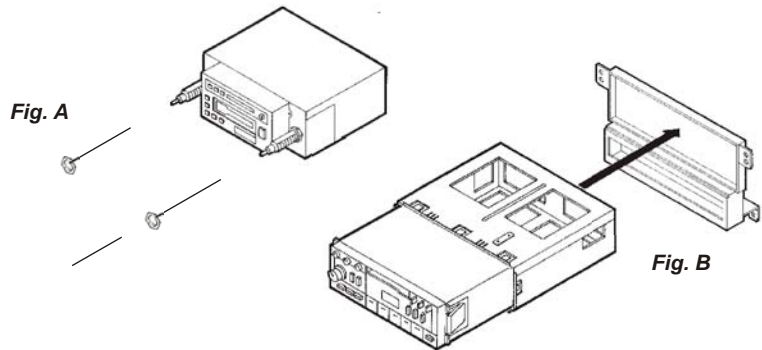

**DIN HEAD UNITS:** Cut and remove the shaft supports from the **Radio Housing**. Slide the DIN cage into the kit and secure by bending the metal locking tabs down. Slide the aftermarket head unit into the cage until secure. (see Fig. B)

3

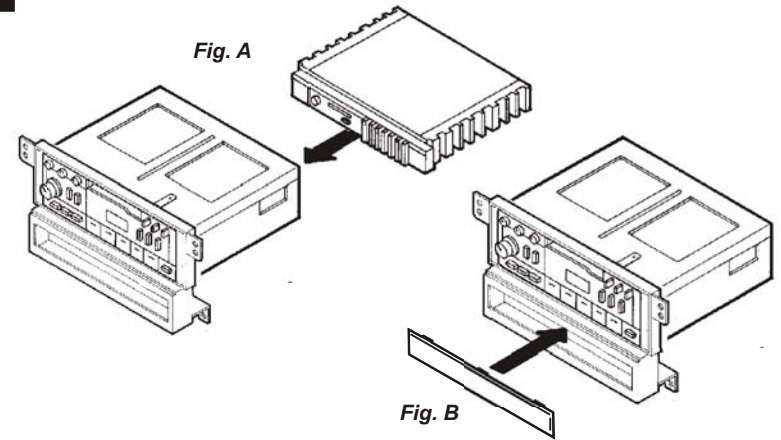

**IF AN EQUALIZER WILL BE INCLUDED:** Slide the aftermarket equalizer into the back of the **Radio Housing**. Using the hardware included with the equalizer, mount the unit to the kit. (see Fig. A)

**IF AN EQUALIZER WILL NOT BE INCLUDED:** Snap the **Equalizer Dummy Plate** into the **Radio Housing**. (see Fig. B)

4

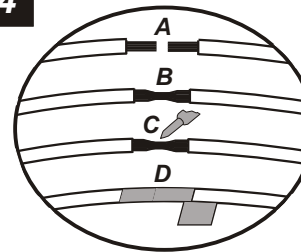

- A) Strip wire ends back 1/2"
- B) Twist ends together
- C) Solder
- D) Tape

Locate the factory wiring harness in the dash. Metra recommends using the proper mating adaptor and making connections as shown. (Isolate and individually tape off the ends of any unused wires to prevent electrical short circuit).

5

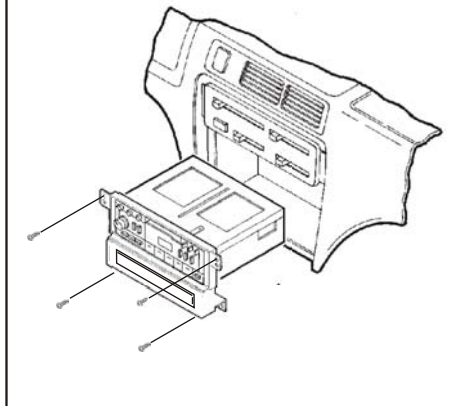

Re-connect the battery terminal and test the unit for proper operation. Mount the head unit/kit assembly to the sub-dash with (4) screws previously removed in step #1.